

INSTALLATION INSTRUCTIONS FOR X10 IN-WALL APPLIANCE MODULE AW12

Switch off appropriate mains fuse and master switch!

Important : 230V - 50Hz - 16A max.

This module can be activated using a toggle switch or a push button connected to it or using X-10 PLC signals. It can be operated using the following X-10 signals: "Address On", "Address Off" and "All Lights On/All Lights Off/All Units Off" if this option is programmed.

The unit will accept either a momentary acting key or a standard wall switch with latching action. All key closures must be to live. If a momentary key is used, the relay changes state each time the key is pressed, as long as the key press lasts for less than 1.75 seconds.

If a standard wall switch with latching action is used, it is assumed the keypress will last for more than 1.75 seconds. In this case the relay changes state on both the closure and release.

This type of response will allow the unit to also perform 2-way control if 2 changeover latching switches are connected in series – as would be the case with 2 way switching.

Installation

To install the AW12, neutral and phase are required at the installation point

- Switch off appropriate mains fuse and master switch!
- Take the wall switch out of the wall box.
- Disconnect all wires from the switch
- Pull an additional Neutral wire if it is missing
- Connect the live and neutral to the terminal wires of the AW12 as described in the drawing.
- Connect the wire from the In-Wall module to the switch.
- Connect the phase to the switch
- Re-fix the wall switch on the wall box
- Switch on mains fuse and master switch

Programming

Default Setting:

The default factory address is A1. If the address and "All lights on/All lights off /All Units Off" option settings aren't known, the default address of A1 can be set by applying power to the unit and sending the address P16 to the unit twice (using any X10 controller - i.e.: TM13 + RF remote control). This can either be just the address "P16" or "P16 On" or "P16 Off". The messages must be sent within 30 seconds of applying power to the unit.

Setting the default address automatically cancels the options to respond to either "All Lights On", "All Lights Off" or "All Units Off".

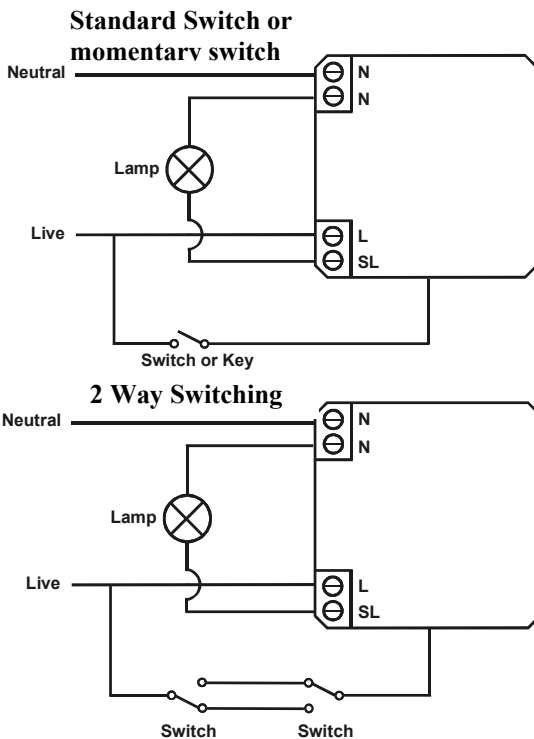

Setting the Address and "All Lights On/All Lights Off/All Units Off" Option

To change the address and set up the "All Lights On/All Lights Off/All Units Off" option the unit must first be put into Program Mode. To enter Program Mode either send "Address On" and "Address Off" in quick succession or press the external Key quickly. After the relay changes state 5 times, with no more than 1.75 seconds between each change of state, the unit will enter Program Mode and the relay will stop responding to indicate that it has entered the Program Mode.

Once in Program Mode the new address can be set by sending an "Address" or "Address On" or "Address Off" message on the new address code twice (using any X-10 controller). If you want to change the code again, just send the revised code twice – as before.

To set the unit to respond to "All Lights On" and/or "All Lights Off" and/or "All Units Off" just send these messages twice on the new address code (using any X10 controller).

Please note: The "All Lights On/All Lights Off /All Units Off" option can be disabled by setting a new address or by returning to the Default Setting – as above.

To return to Run Mode: either send "Address On", "Address Off" or press the key quickly (no more than 1.75 seconds between keypress). After 5 keypresses or "On/Off" message, the relay will start to respond, indicating that the unit is back in Run Mode.

If no action is taken, the unit will automatically return to Run Mode after 60 seconds.

Important notice:

After the installation of the X-10 controllers, all receiver modules have first to be checked for correct function and address!

Technical Data:

Supply voltage: 230 V +10% -15% 50 Hz, Supply current: < 20 mA capacitive. Making capacity: 2000 W (incandescent lamp), 3 A (motors), 16 A (resistive loads)

TROUBLESHOOTING

In general X-10 products are extremely easy to install and very reliable. Like other electronic equipment, they do require proper set-up for correct operation. If you experience a problem, go through these troubleshooting aids.

Having trouble with just one device...

- Does the X-10 controller work with other modules ? If it doesn't refer to « Things to check if NOTHING works ».
- Is the module you are trying to control correctly connected to the mains ?
- Is the switch for the light or appliance you are trying to control turned on ?
- Does the light or appliance work OK if you connect it directly to the mains ?
- Is the module connected to a surge protector ? A surge protector might block signals from your interface or controller.
- Noise on your house wiring could cause a module not to work at all or only work intermittently. Although not very likely, as special circuitry has been designed into the X-10 modules and CE product standards require that electrical devices do not generate noise. However check to see if any of these things are operating when you are having problems :

Wireless intercoms in transmit (talk) mode, Baby Monitors that transmit over your house wiring, Wireless Doorbells that use the house wiring, Laser Printers, Electric Motors (old ones), Electric hair dryers, Electric shavers, Vacuum cleaners, Floor scrubbers, Electric Carving Knives, Food Processors, Blenders, Mixers, Micro-wave ovens.

To determine if you have an interference (noise) problem, unplug anything that you suspect might be causing the problem and try controlling your device again. Noisy devices could be anywhere in your house, but start looking around the area that you are having a problem.

There is a device available called a Plug-in Noise Filter that will reduce the noise injected onto the house wiring from a noisy device. You plug the noisy device into the filter and then plug the filter into the wall outlet. For more information, contact your local distributor.

- If you cannot locate any things that are interfering with your system, try using a different Module of the same type at this same location in your home. Remember to set the correct House Code/Unit Code on the new module. - If this fixed the problem, the original module is possibly defective.
If no modules work in that location, you may have a problem with the wall outlet, you may have a noise problem as described above, or you may have a problem with your house wiring. Contact your local electrician.

Things to check if NOTHING works.....

- Is the X-10 controller plugged into a working outlet? Is the outlet controlled by a wall switch? If so, is it turned on?
- Is the Housecode set correctly ?
- If you still cannot control any modules, plug your controller and module into the same outlet (using a non surge protected outlet strip, if necessary). See if you can control this module. If not, contact your local distributor for help.
- If it does work correctly with the controller and the module into the same outlet, try plugging the module in where you originally had it. If it doesn't work when you plug the module in somewhere else in your home (try several different locations and several modules of the same type), contact your local dealer for help.